

USER'S MANUAL



FEATURE INTRODUCTION

AZZA continues its tradition of bringing its customers the best cases with optimal functionality and appealing aesthetics.

Supports Longest VGA Card on the Market

XT-1 supports VGA card up to 340 mm, the longest on the current market.

Easy Swap Slot

An Easy Swap Slot is located at the bottom, allowing for easy installation of the HD without the need to unscrew any screws.

Exceptional Cooling Performance

XT-1 has a total of four fans, strategically placed on four sides of the chassis to cool all the components in your system. If additional cooling is needed, the case supports up to two 120mm water cooling radiators.

Easy Installation

Featuring a tool-less design and a HDD holder that turns 90 degrees, installing your 5.25" devices and HDD becomes as easy as 1-2-3.

Cable Management

XT-1 features a cable management compartment, allowing your components to be organized and the airflow unimpeded.

Removable/Exchangeable Front and Top Grilles

Featuring two front and two top decorative grilles that can be either removed or be exchanged to different colors, XT-1 gives you the freedom to change its aesthetics.

SPECIFICATIONS

Model:	
Model Name	XT 1
Model No	CSAZ-XT 1B/CSAZ-XT 1W
Spec:	
Type	ATX Full Tower
Color	Black/Black (inside chassis)/White/White (inside chassis)
Material	Japanese SECC Steel
Side Panel Window	Yes
With Power Supply	No
CPU Cooler Compatibility	up to 190mm
Motherboard Compatibility	XL-ATX, Full ATX, Micro ATX
Power Location	Rear bottom
Expansion:	
External 5.25" Drive Bays	4
External 3.5" Drive Bays	1
Internal 3.5" Drive Bays	6
Easy Swap 2.5" SSD Slot	1
Easy Swap 3.5" HDD Slot	1
Expansion Slots	8
Front Ports	2x USB 3.0, 2xUSB 2.0, HD Audio
Cooling System:	
230mm Fan	1x230mm Red/Blue LED fan on the top
140mm Fan	1x140mm Red/Blue LED fan on the side, 1x140mm LED in front
120mm Fan	1x120mm fan in rear
Physical Spec:	
Dimensions(HxWxD)	22.3"x8.1"x20.3" (HxWxD)
Weight	22 lbs
Feature:	
Exceptional Cooling System	1x230mm fan located on the top, for hot air exhaustion
Total 4 Fans	1x140mm LED fan located on the side, for cool air intake
	1x120mm LED fan located in the front, for HDD cooling
	1x120mm fan located in the rear, for hot air exhaustion
Easy Swap Slot for 3.5" HDD and 2.5" SSD	1x Easy Swap HDD tray for easy installation of HDD, no need to open the side window or un-screw any screw to install HDD.
Optimum Capacity water cooler	Support up to 2x120mm water cooling radiators.
Support longest VGA card	Accommodate VGA card up to 340mm
USB 3.0 Ready	2xUSB 3.0, 2xUSB 2.0
Maximum Compatibility	Accommodate XL-ATX, Full ATX, Micro ATX and all kinds of Nvidia , ATI long VGA card up to 340mm.
Easy installation of CPU cooler	A cut-off hole is designed for easy installation of CPU cooler, no need to take out the motherboard.

PORTS

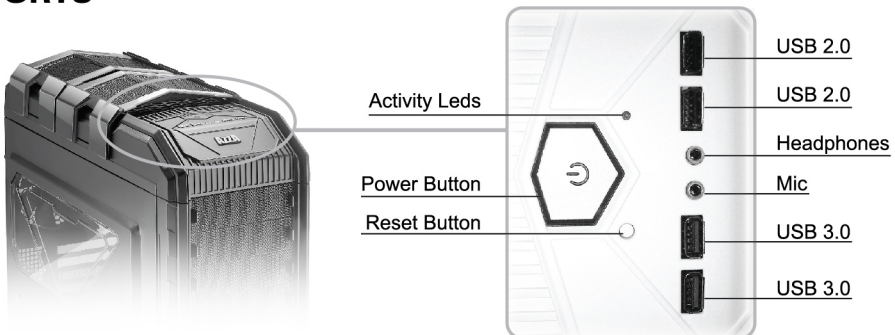



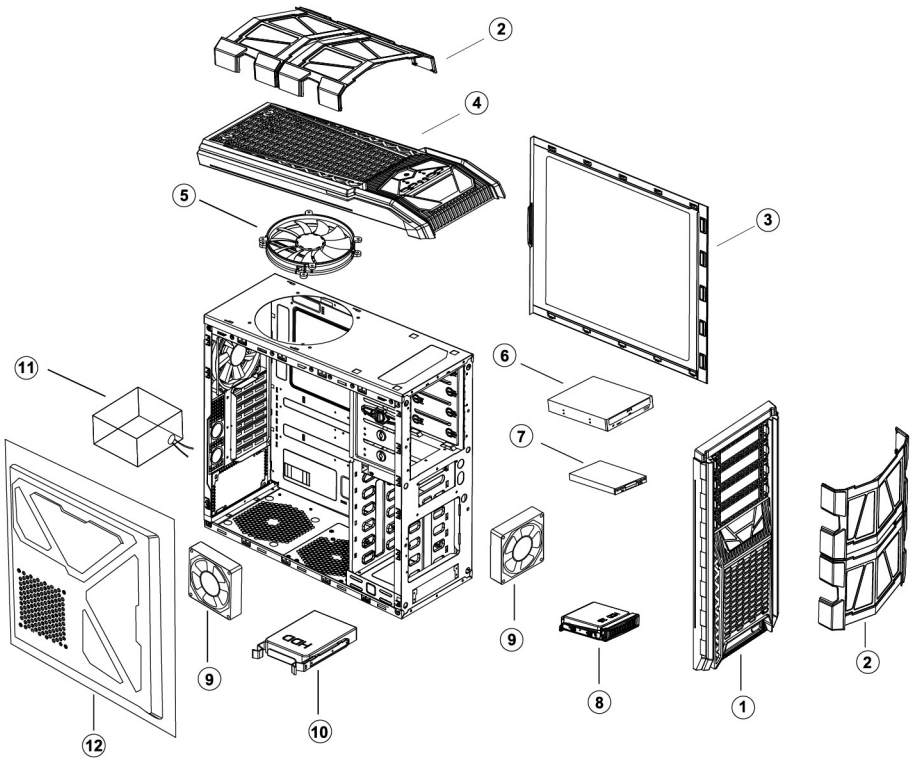







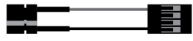

PART LIST



1	Front Panel	2	Mask	3	Side Panel
4	Top Panel	5	23cm Fan	6	CD-ROM/DVD-ROM*
7	Floppy Drive Bay*	8	HDD Cage	9	14cm Fan
10	HDD Cage	11	Power Supply*	12	Side Panel

* Not Included

ASSEMBLY KITS

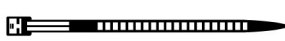
		Screws for Motherboard and Hard Disk 16 pcs		Speaker 1 pc
		Screws for FDD & Card Reader 12 pcs		Cable Tie 2 pcs
		Screw Nuts for Motherboard 5 pcs		5.25" to 3.5" Drive Bay 1 pc
		Manual Screws for CD-Rom and DVD-Rom 4 pcs		Mask 4 pcs
	T-Shaped Reusable Tie 2 pcs			

INSTALLATION INTRODUCTION

1. Open the Side panel

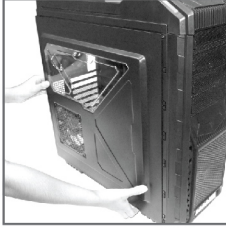
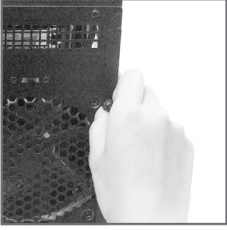

- Place the case upright on a flat surface, so the rear panel (power supply and expansion slots) is facing you.
 - Remove the tool-less screws from the rear panel of the case.
 - Slide the side panel towards the rear.
- ***Be sure to un-plug the side panel fan connector before removing the side panel.

2. Power Supply Installation

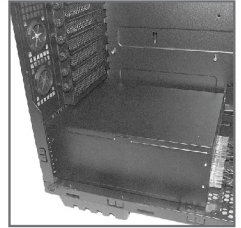
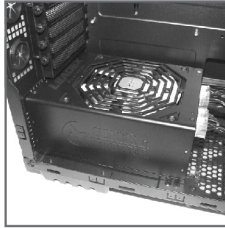
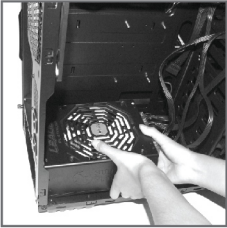

- Place the power supply into its designated location.
- Secure the power supply to the case with the screws provided.
- The power supply unit can be installed with the fan facing either up or down. To optimize airflow and efficiency, it is recommended that the PSU fan be installed facing down.

3. Motherboard Installation

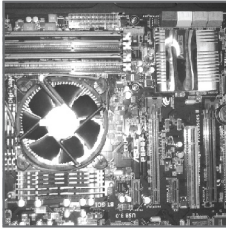
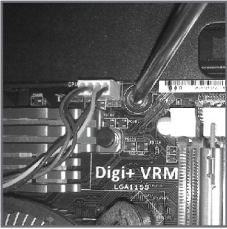

This manual is not designed to cover CPU, RAM, or expansion card installation.

Please consult the motherboard manual for any specific mounting instruction and troubleshooting.

Before proceeding, please check the manual for your CPU cooler for necessary steps to take before installing the motherboard.

- Lay down the case with the motherboard base facing up.
- Make sure you have the appropriate I/O shield panel for the motherboard. The I/O shield panel is a standard accessory that comes with your motherboard.
- Screw in the motherboard brass standoffs to the threaded holes that are lined up with the motherboard.
- Place the motherboard on the brass standoffs. Screw in the motherboard to the brass standoffs with the provided Phillips-head screws.

4. 5.25" Optical Drive Installation

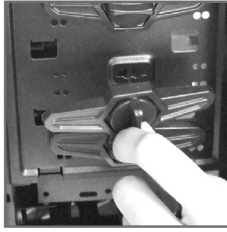

- Remove the 5.25" optical drive mesh grille cover by pressing both clips outward. (as shown in the picture).
- Remove the tool-less clip by turning it counter-clockwise.
- Insert the 5.25" optical drive into the drive bay.
- When the screw holes of the case are lined up with the optical drive, the optical drive can be locked in by turning the tool-less clip clockwise.

5. 3.5" HDD Installation

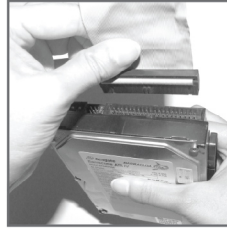

- Press both tabs and pull to remove the HDD holder (as shown in the picture).
- Gently bend the HDD holder & place the HDD drive into the holder.
- Place the holder back into the drive slot and connect the HDD connectors to complete the installation.

5-1. 2.5" SSD Installation

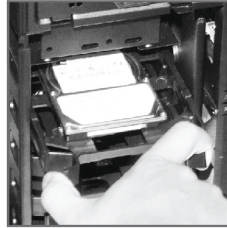
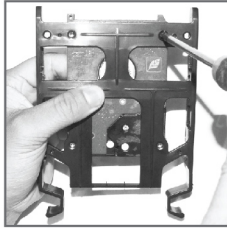

- Press both tabs and pull to remove the HDD holder (as shown in the picture).
- Place the 2.5" SSD into the HDD holder 2.5" screw position and lock the SSD by the four supplied installation screws.
- Place the holder back into the drive slot and connect the SSD connectors to complete the installation.

6. 3.5" HDD Front Panel Tool-less Tray Installation

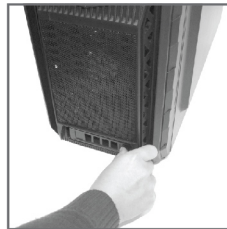
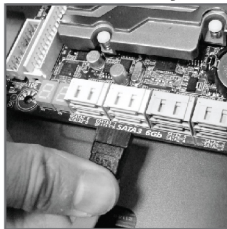
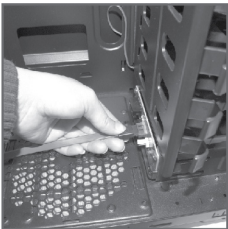

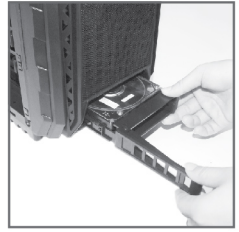
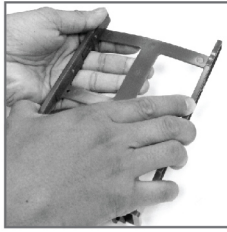
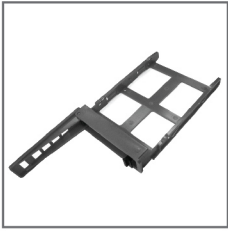

- Connect the SATA cable between the back panel easy swap PCB and the motherboard.
- Release the HDD slot by pressing the tab outward.
- Swing the handle outward then pull, the HDD holder will be released from the Easy Swap PCB.
- Remove the HDD holder from the slot.
- Place and install the HDD or SSD drive into the holder
- Insert the HDD holder back to the tray until it is clicked into its place.
(HDD tray will connect the Easy Swap PCB)
- HDD and SSD tray can be removed without opening the side panel.

Special Note: Please be sure the computer is turned off during hard drive installation.

7. Top Panel Fan & Front Panel Fan Removal

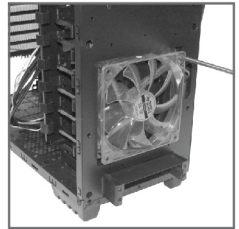
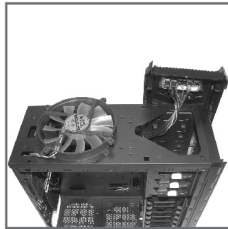
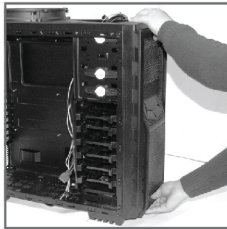
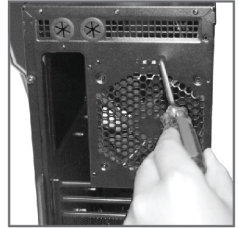

Top Panel Fan

- Unscrews the screws
- Push the top panel toward the front to unlock it from the case.
- Remove the top panel.
- Unscrew the top panel fan screw.
- Remove the top panel fan.

Front Panel Fan

- Remove the front panel by pulling it out from the case.
- Unscrew the 4 fan screws.
- Remove the fan's wiring through the chassis hole.
- Remove the front panel fan, which can be replaced by any standard 12cm fan.

8. Fan Filter Cleaning

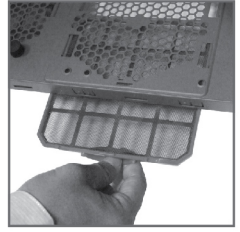
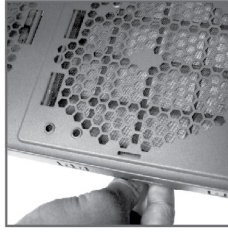
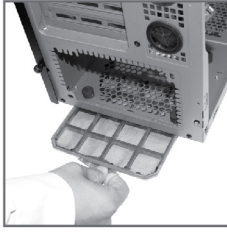
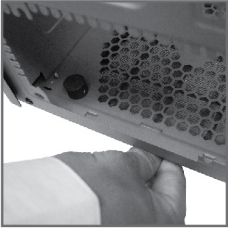

Power Supply Filter

- Gently remove the filter by pressing the filter open tab, then pull out the filter as shown in the picture.

Bottom Panel Filter

- Gently remove the filter by pressing the filter open tab, then pull out the filter as shown in the picture.

Filter Cleaning Procedures

- Please use only water to clean the filter.
- Please do not use any detergents.
- Restore the filter only after it is completely dried.

9. Front & Top Mesh Grill Mask



- Front panel grille can be glided up or down to cover the upper 5.25" bays or the lower 3.5 bays.
- Top panel grille can be glided toward the front or the rear to cover the front top panel or the rear fan position.

XT1

www.azzatek.com

AZZA
ONE VISION, ONE MISSION

AZZA (USA) Technology Ltd.

Tel : +1909-869-0658 Fax: +1909-869-7390
201 Lemon Creek Dr. # B Walnut, CA 91789 U.S.A
131007-2